

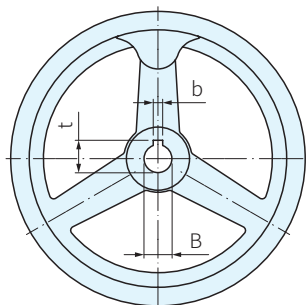

本體		把手	
材質	處理	材質	處理
鋁合金	去毛頭，輪緣拋光	鋼	鍍鋅

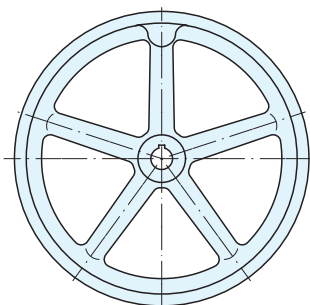

輪幅=3



輪幅=5

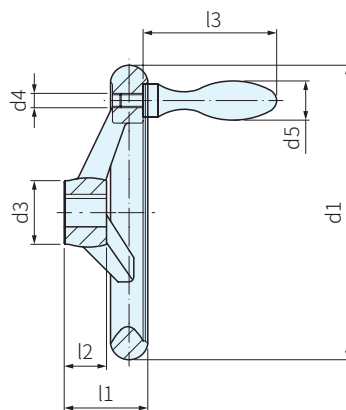

B(小) 品號	質量 g	庫存	B(大) 品號	質量 g	庫存	d1	B(H7)		d3	d4	d5	l1 ≈	l2	l3 ≈	輪幅	特性	把手 24450
							小	大									
24590.0400	150	•	24590.0401	150	•	80	10	12	24	M6	16	29	16	50	3	無鍵槽 有固定 把手	16
24590.0405	210	•	24590.0406	210	•	100	10	12	26	M6	16	33	17	50	3		16
24590.0410	340	•	24590.0411	340	•	125	12	14	28	M8	20	36	18	64	3		20
24590.0420	615	•	24590.0421	615	•	160	14	16	32	M10	25	40	20	80	3		25
24590.0430	970	•	24590.0431	970	•	200	18	22	38	M10	25	45	24	80	3		25
24590.0440	1860	•	24590.0441	1860	•	250	22	26	45	M12	32	50	28	100	5		32
24590.0445	2860	△	24590.0446	2860	△	315	26	30	53	M12	32	56	33	100	5		32
24590.0450	4210	△	24590.0451	4210	△	400	30	34	65	M16	36	63	38	112	5		36
24590.0500	150	•	24590.0501	150	•	80	10	12	24	M6	16	29	16	50	3		有鍵槽 有固定 把手
24590.0505	210	•	24590.0506	210	•	100	10	12	26	M6	16	33	17	50	3	16	
24590.0510	330	•	24590.0511	330	•	125	12	14	28	M8	20	36	18	64	3	20	
24590.0520	610	•	24590.0521	610	•	160	14	16	32	M10	25	40	20	80	3	25	
24590.0530	960	•	24590.0531	960	•	200	18	22	38	M10	25	45	24	80	3	25	
24590.0540	1860	•	24590.0541	1860	•	250	22	26	45	M12	32	50	28	100	5	32	
24590.0545	2860	△	24590.0546	2860	△	315	26	30	53	M12	32	56	33	100	5	32	
24590.0550	4210	△	24590.0551	4210	△	400	30	34	65	M16	36	63	38	112	5	36	

訂貨： 交期： 天 ·
24590.0400 天 △

DIN6885 鍵槽規格									
B	10	12	14	16	18	22	26	30	34
b	3.0	4.0	5.0	5.0	6.0	6.0	8.0	8.0	10.0
t	11.4	13.8	16.3	18.3	20.8	24.8	29.3	33.3	37.3

PS. 備註

- 可搭配手輪端蓋SGR184、SGR184.5、22270，請參閱本單元
- 固定把手24450，請參閱把手單元

